

INFLUENCE OF RADIATION ENERGY AND ANGLE OF INCIDENCE ON THE UNCERTAINTY IN MEASUREMENTS BY GM COUNTERS

by

Koviljka STANKOVIĆ¹ and Miloš VUJISIĆ²

Received on March 19, 2008; accepted in revised form on April 1, 2004

This paper discusses the influence of radiation energy and angle of incidence as possible sources of uncertainties in measurements performed by GM counters. Based on the detection efficiency of GM counters, it has been concluded that the energy of incident radiation does not contribute to the overall uncertainty. The angle of incident radiation does contribute to overall uncertainty, but only in the case of gamma radiation detection. In that case, the uncertainty should be determined by using geometrical probability.

Key words: uncertainty in measurements, GM counter, radiation energy, angle of incidence

INTRODUCTION

In the previous paper [1], by means of a process of detecting ionizing radiation by GM counters, the following potential sources of uncertainty were identified: the energy and incident angle of radiation, counter dead time, resolution of the instrument reading system, instrument calibration errors, influence of background radiation, the stochastic nature of this phenomenon, and the influence of the overvoltage phenomenon in measuring systems (in their wire structures) induced by environmental electromagnetic radiation. It has been said that the energy of incident radiation determines the number of free, potentially initial electrons in the counter's tube and contributes to the stochastic discharge time of the counter, directly determining the nature of type A uncertainty. It has also been said that the angle of incident radiation con-

tributes to type A uncertainty, because the number and position of free electrons, created by ionization, depend on this angle. Nothing else was said about the energy and angle of incident ionizing radiation as sources of uncertainties. Other identified sources of uncertainties are theoretically and experimentally analyzed in detail. Therefore, the aim of this paper is to consider the influence of the energy and incident angle of ionizing radiation on measurements performed by GM counters.

DETECTION EFFICIENCY OF GM COUNTERS

Because a single ion pair formed within the filling gas of the GM tube can trigger a full Geiger discharge [2, 3], the counting efficiency for any charged particle that enters the active volume of the tube is essentially 100%. In most practical situations, effective efficiency is therefore determined by the probability that the incident radiation penetrates the window of the tube without absorption or backscattering. With alpha particles, the absorption within the window is the major concern, even if windows with a thickness as small as 1.5 mg/cm² are used.

GM counters are not used for neutron detection, because conventional gases have an unacceptably low cross-section for thermal neutron capture. It is possible to use gases with a high capture cross-section, such as BF₃ but, in that case, proportional counters are

Technical paper

UDC: 539.1.074.2:621.371.3

BIBLID: 1451-3994, 23 (2008), 2, pp. 41-42

DOI: 10.2298/NTRP0801041S

Authors' addresses:

¹ Radiation and Environmental Protection Department,
Vinča Institute of Nuclear Sciences
P. O. Box 522, 11001 Belgrade, Serbia

² Faculty of Electrical Engineering,
University of Belgrade
P. O. Box 3554, 11001 Belgrade, Serbia

E-mail address of corresponding author:
kstankovic@vin.bg.ac.yu (K. Stanković)

much more suitable. In the proportional counter, neutron-induced events are of much larger amplitude than pulses generated by background gamma rays and are, therefore, easily distinguished. In the Geiger region, all pulses are of the same amplitude and gamma ray discrimination is not possible. Fast neutron gas-filled detectors are normally operated as proportional counters, rather than as GM counters, to take advantage of the spectroscopic information provided only in the proportional region.

In any gas-filled counter, the detection of gamma rays is based on the creation of secondary electrons in the thin inner wall surface of the tube from which electrons can reach the gas and create ions. Because only a single ion pair is required, the secondary electron needs only to barely emerge from the wall near the end of its track in order to generate a pulse from a GM tube. Detection efficiency for gamma rays therefore depends on two separate factors: the probability that the incident gamma ray interacts in the wall and produces a secondary electron and the probability that the secondary electron reaches the filling gas before the end of its track. Detection efficiency is highest when the tube wall is constructed of high atomic number material. GM tubes with a bismuth cathode ($Z = 83$) have been widely used. Even in this case, gamma ray detection efficiency is small and does not exceed several percents, which means that the random process of gamma ray detection belongs to the Poisson distribution.

INFLUENCE OF RADIATION ANGLE OF INCIDENCE ON MEASUREMENT UNCERTAINTY

Taking into account the above mentioned, it can be concluded that:

- the energy of the incident radiation does not contribute to the overall uncertainty in measurements performed by GM counters, and
- the angle of incident radiation does contribute to the overall uncertainty in measurements performed by

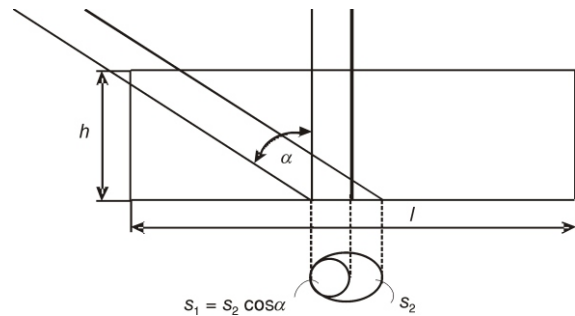

Figure 1. Measurement uncertainty dependence on the incident radiation angle

GM counters, but only in the case of gamma radiation detection.

The way the measurement uncertainty depends on the incident radiation angle is based on a geometrical probability, as shown in fig. 1.

When the incident radiation penetrates the tube wall, the area of interaction (s_1 and s_2 shown in fig. 1) depends on the radiation angle with a relation of $1/\sin\alpha$, which can be seen from the first approximation and, therefore, the contribution of incident gamma radiation angle on measurement uncertainty can be determined from:

$$\frac{\lambda}{\cos \alpha}, \quad 0 < \alpha < \arccos \frac{h}{\sqrt{h^2 + l^2}}$$

where λ represents the variance of the Poisson distribution when the incident gamma radiation is perpendicular to the GM tube.

REFERENCES

- [1] Stanković, K., Arandjić, D., Lazarević, Dj., Osmokrović, P., Expanded and Combined Uncertainty in Measurements by GM Counters, *Nuclear Technology & Radiation Protection*, 22 (2007), 2, pp. 64-70
- [2] Knoll, G. F., Radiation Detection and Measurement, John Wiley and Sons, New York, USA, 1979
- [3] Osmokrović, P., Basics of Nuclear Physics (in Serbian), *Akademski misao*, Belgrade, 2008

Ковиљка СТАНКОВИЋ, Милош ВУЈИСИЋ

УТИЦАЈ ЕНЕРГИЈЕ И УГЛА УПАДНОГ ЗРАЧЕЊА НА МЕРНУ НЕСИГУРНОСТ ГАЈГЕР-МИЛЕРОВОГ БРОЈАЧА

У раду је описан утицај енергије и угла упадног зрачења као могућих извора мерне несигурности при мерењима извршеним Гајгер-Милеровим бројачима. На основу ефикасности детекције Гајгер-Милеровог бројача, може се закључити да енергија упадног зрачења не утиче на укупну мерну несигурност. Угао упадног зрачења утиче на мерну несигурност, али само у случају детекције гама зрачења. У том случају, мерна несигурност може да се одреди користећи геометријску вероватноћу.

Кључне речи: мерна несигурност, Гајгер-Милеров бројач, енергија зрачења, упадни угао зрачења